

Gewicht: 2,8 kg (A)  
8,4 kg (S)

Nenndruck: 250 bar (A)  
350 bar (S)

Aufnahmebohrung  
C-16-2  
siehe Maßblatt-Nr.:  
IK-100-169

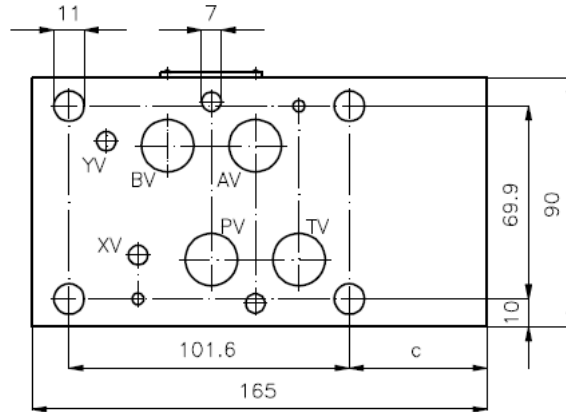
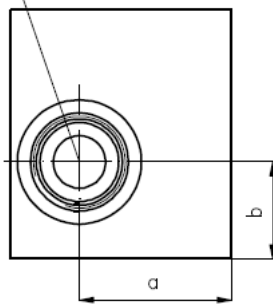

MGZ-16.-P2/T1  
MGZ-16.-A2/T1  
MGZ-16.-B2/T1

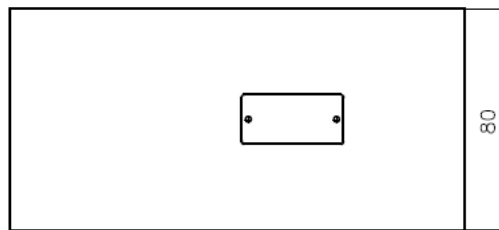

MGZ-16.-PM1/PV2+PD-B08

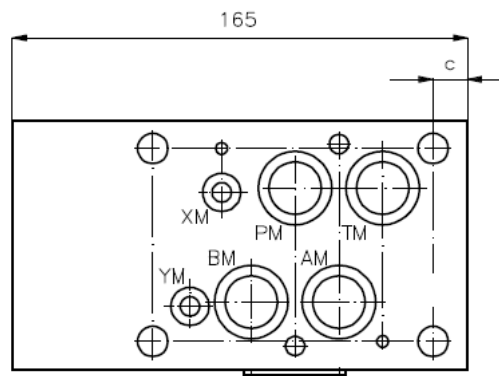
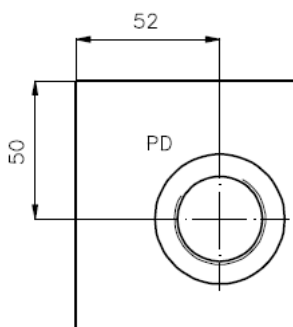

MGZ-16.-PM2/PV1  
MGZ-16.-BM2/BV1  
MGZ-16.-BM2/BV1+A

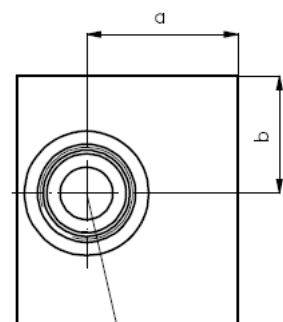

Aufnahmebohrung  
C-16-2  
siehe Maßblatt-Nr.:  
IK-100-169

Typ	a	b	c
MGZ-16.-PM1/PV2+PD-B08	25	42.5	15
MGZ-16.-PM2/PV1	55	42.5	12.5
MGZ-16.-P2/T1	55	45	50
MGZ-16.-A2/T1	50	35	50
MGZ-16.-BM2/BV1	55	45	12.5
MGZ-16.-B2/T1	50	45	50

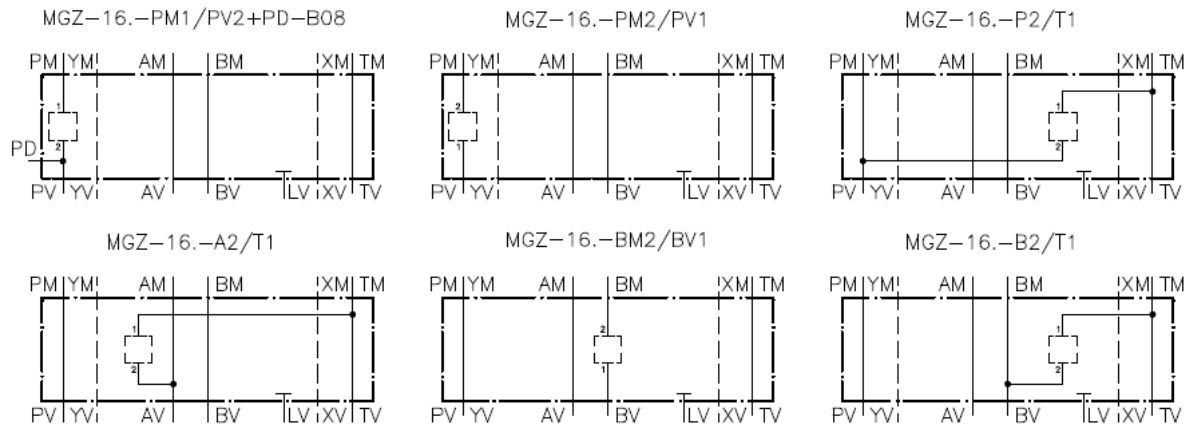

**Bestell-Schlüssel:**

**Bestell-Beispiel:**

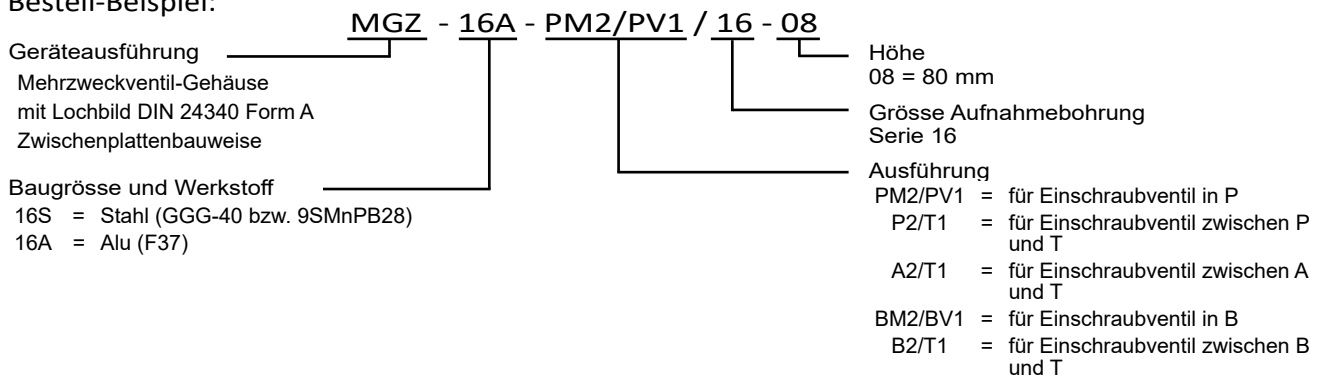

mit Druckspeicheranschluss

**Bestell-Schlüssel:**

**Bestell-Beispiel:**

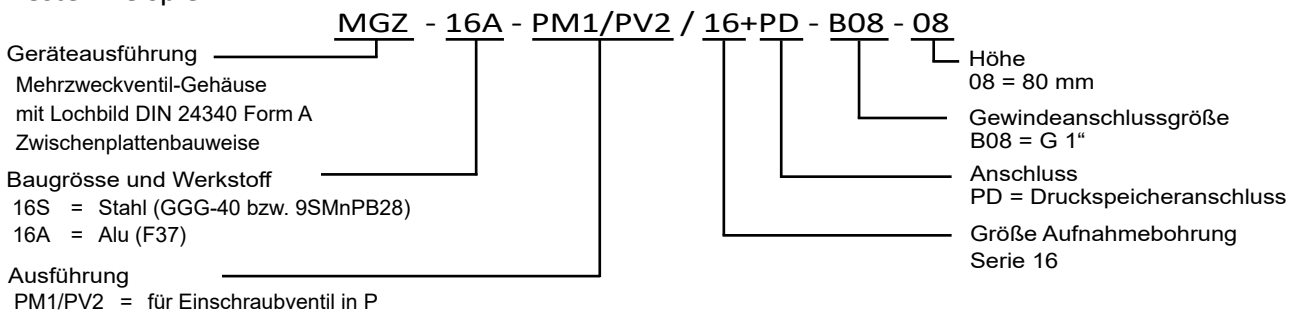

enthalten: 4 St. O-Ring 22,22 x 2,62  
2 St. O-Ring 9,19 x 2,62