

# Stromgleichrichter NG 10 (Zwischenplatte)

SG-10. oder QG-10.

**Gewicht:** .GZ-10.: ca. 1.2 kg (A) ; ca. 3.4 kg (S)  
.GA-10.: ca. 1.8 kg (A) ; ca. 4.9 kg (S)

**Nenndruck:** 250 bar (A)  
350 bar (S)

**Nennstrom:** 50 l/min

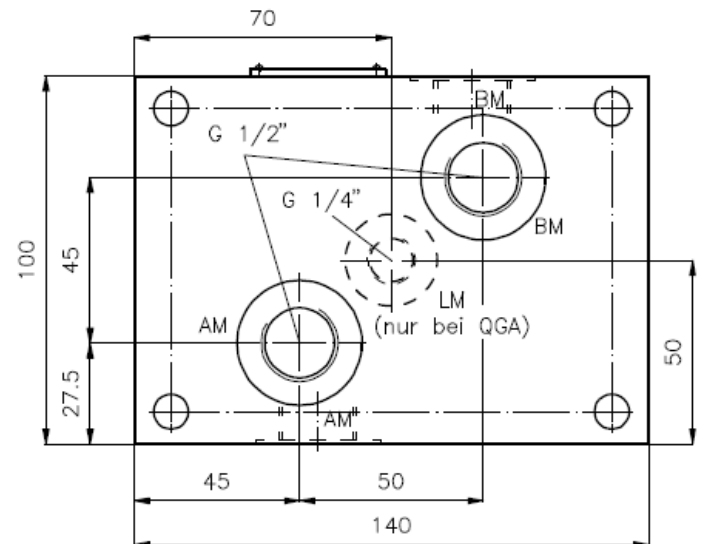
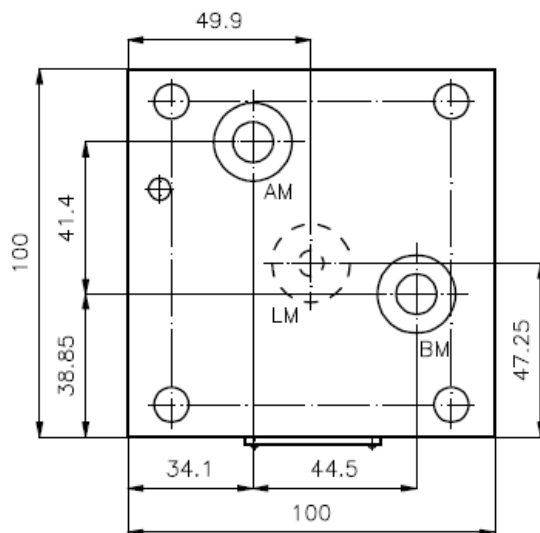
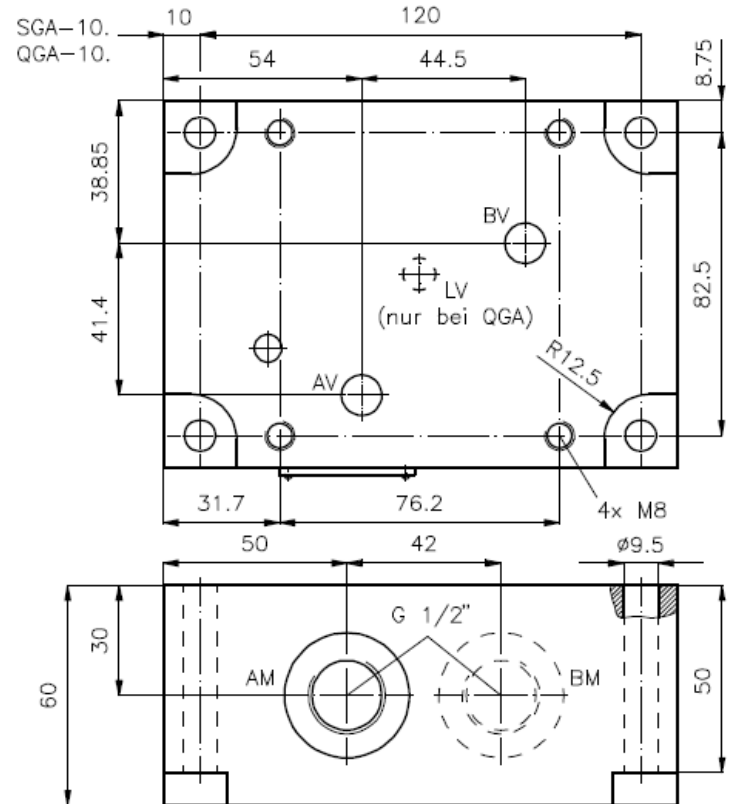
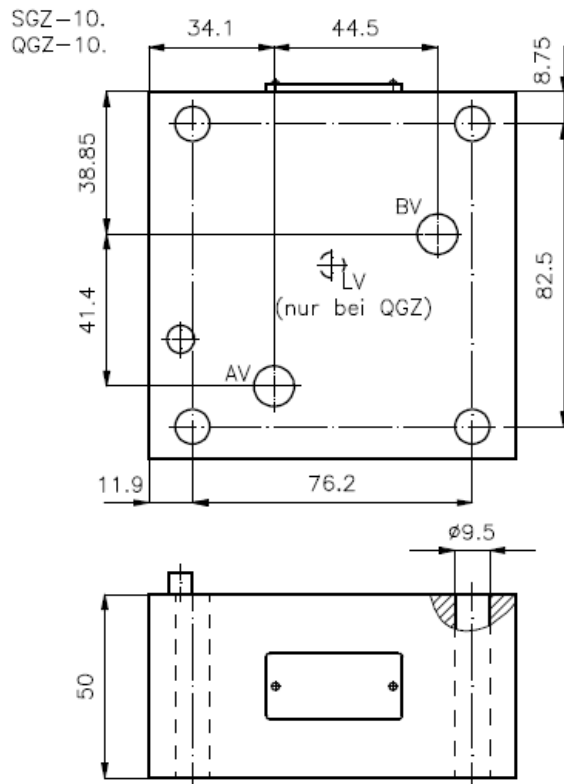

Symbol:

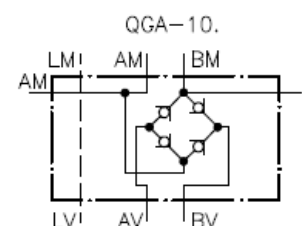
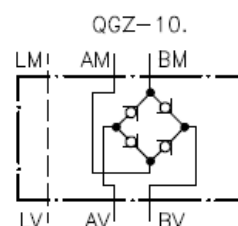
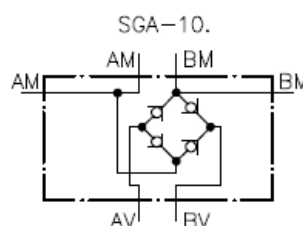
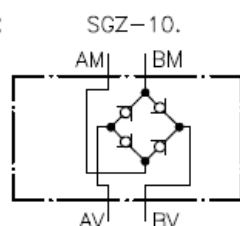

**Zum Lieferumfang gehoeren:** 4 Stck. O-Ring  $\varnothing 17.12 \times 2.62$  bei SGZ-10.  
5 Stck. O-Ring  $\varnothing 17.12 \times 2.62$  bei QGZ-10.