

Mehrzweck-Gehäuse-Zwischenplatte NG 16 (von PM2 nach PV1)

MGZ-16.-PM2/PV1/20-09

Gewicht: ca. 3.8 kg (A)
ca. 10.6 kg (S)

Nenndruck: 250 bar (A)
350 bar (S)

Aufnahmebohrung
C-20-2
siehe Massblatt-Nr.:
IK-100-209

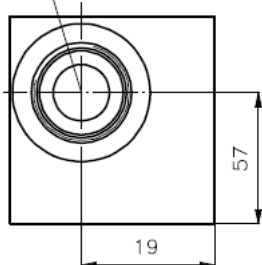

MGZ-16.-AM2/AV1/20

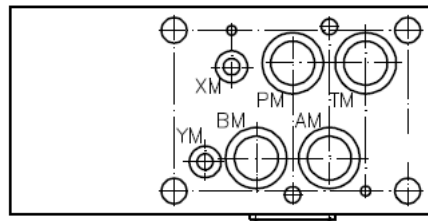
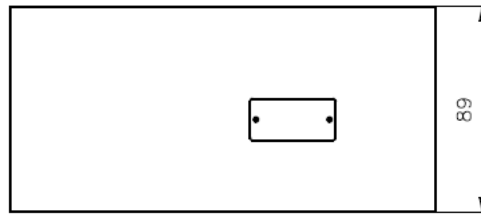
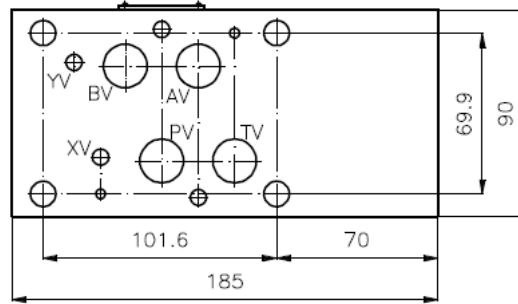

MGZ-16.-BM2/BV1/20
MGZ-16.-PM2/PV1/20 (Klammermass)

Aufnahmebohrung
C-20-2
siehe Massblatt-Nr.:
IK-100-209

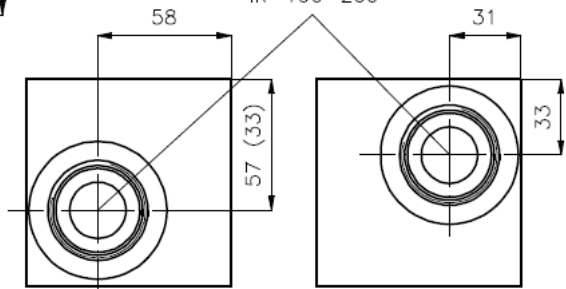

MGZ-16.-PM1/PV2/20

Symbol:

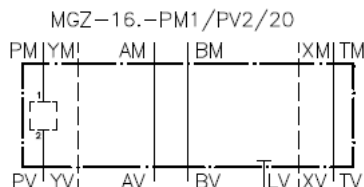
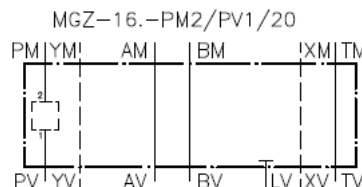
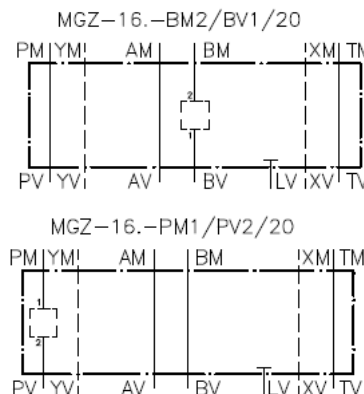
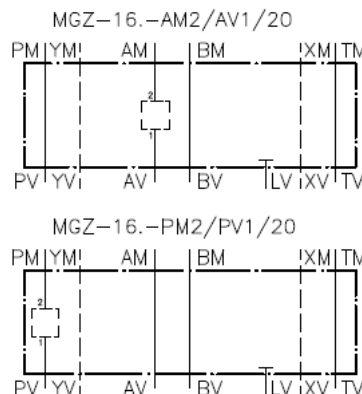

Bestell-Schlüssel:

Bestell-Beispiel:

MGZ-16A-AM2/AV1/20

Geraeteausfuhrung _____ Aufnahmebohrung
Baugroesse und Werkstoff _____ Serie 20
16A = Alu (F 37) _____ Ausfuhrung
16S = Stahl (9SMnPb28K bzw. GGG-40) _____

Zum Lieferumfang gehoeren: 4 Stck. O-Ring 22.22 x 2.62
2 Stck. O-Ring 9.19 x 2.62