

# Umlenk-Platte NG 16 (P mit B, T mit A verbunden, X, Y und L verschlossen)

UP-16.-PB+TA

**Gewicht:** VSP : ca. 1.1 kg (A); ca. 3.4 kg (S)  
UP : ca. 1.8 kg (A); ca. 5.5 kg (S)

**Nenndruck:** 250 bar (A)  
350 bar (S)

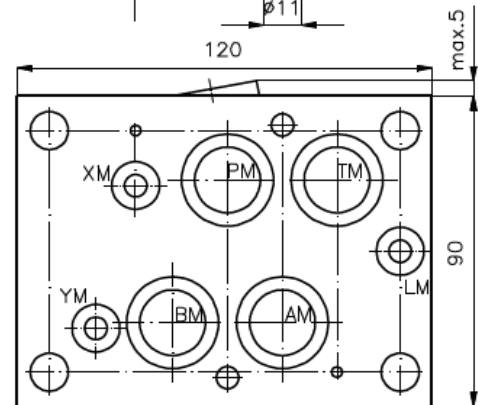
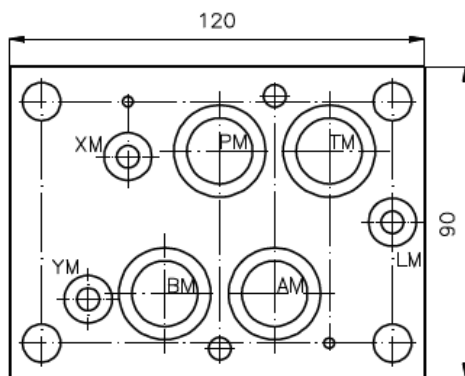
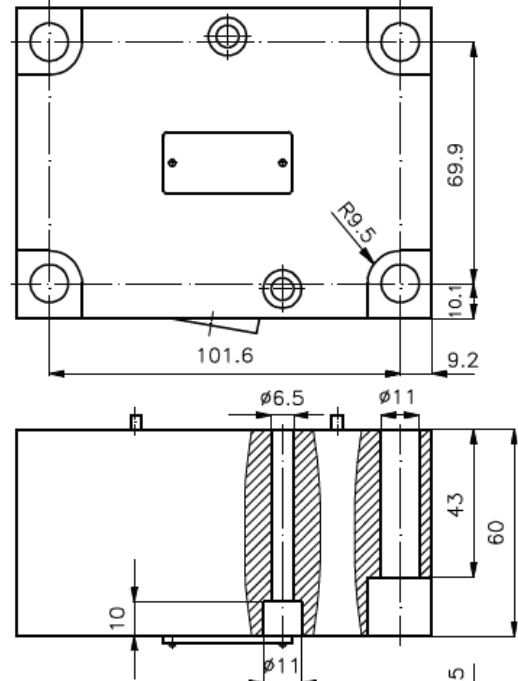
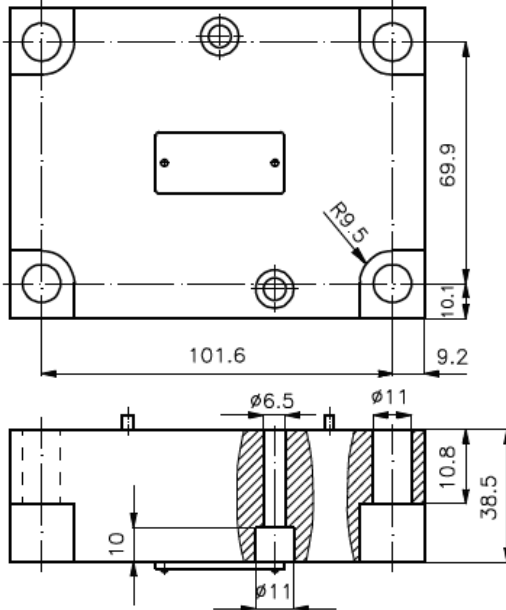

VSP-16.

UP-16.-PT  
UP-16.-PT-XY  
UP-16.-PAB  
UP-16.-PA+TB  
UP-16.-PB+TA  
UP-16.-PB+TA+XY

Symbol:

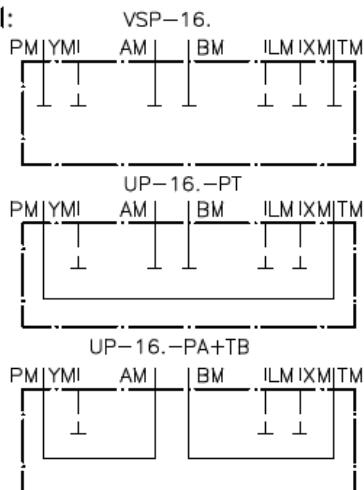

Zum Lieferumfang gehören:

4 Stck. O-Ring  $\varnothing 22.22 \times 2.62$   
3 Stck. O-Ring  $\varnothing 9.19 \times 2.62$

Hinweis:

Erforderliche Befestigungsschrauben:

2 Stck. M6 x 35 DIN 912 und 4 Stck. M10 x 35 DIN 912 (VSP-16.)  
2 Stck. M6 x 60 DIN 912 und 4 Stck. M10 x 60 DIN 912 (UP-16.-..)