

3SLH-...-B..

Gewicht: s. Tabelle

Nenndruck: 250 bar (A)
350 bar (S)

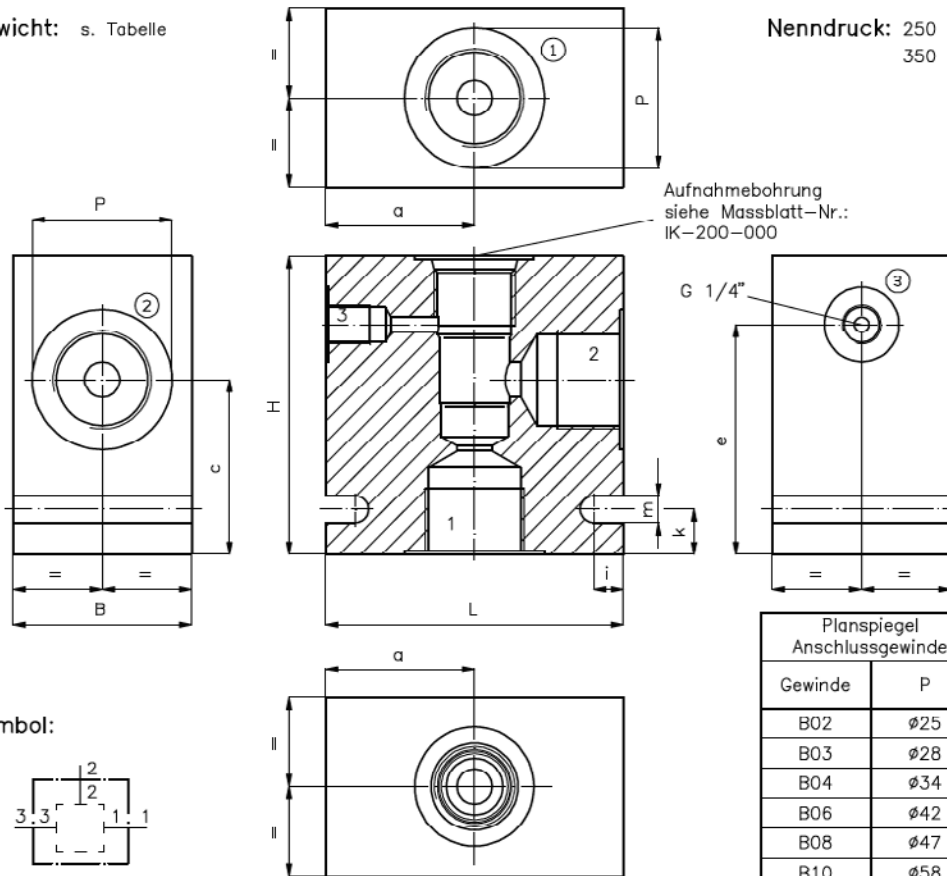

Planspiegel Anschlussgewinde	
Gewinde	P
B02	ø25
B03	ø28
B04	ø34
B06	ø42
B08	ø47
B10	ø58
B12	ø65

Symbol:

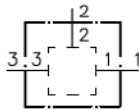

Typ	L	B	H	a	c	e	i	k	m	Gewicht (kg)	
										A	S
3SLH-10.-B..	70	40	70	35	38	54.5	10	10	7	0.50	1.30
3SLH-10.-B06	80	50	80	40	48	64.5	10	10	7	0.80	2.10
3SLH-12.-B..	100	60	100	50	58	79	10	15	9	1.30	3.10
3SLH-16.-B..	100	60	100	45	61	82	10	15	9	1.30	3.10
3SLH-20.-B..	120	80	120	50	69	99	10	25	11	2.80	6.70

Bestell-Schlüssel:

Bestell-Beispiel:

3SLH-10A-B04

3S-Wege-Ventil-Gehäuse

Anschluss-Gewindegröße 1; 2

Baugröße

Serie 10

Serie 16

- Serie 10
- Serie 12
- Serie 16
- Serie 20

B02 = G 1/4"

B03 = G 3/8"

B04 = G 1/2"

B06 = G 3/4"

B06 = G 3/4"

B08 = G 1"

Serie 12

Serie 20

B04 = G 1/2"

B06 = G 3/4"

B08 = G 1"

B08 = G 1"

B10 = G 1 1/4"

B12 = 1 1/2"

Werkstoff

A = AlCuMgPb

S = GGG-40 bzw.
9SMn28K