

2-Wege-Ventil-Gehäuse mit 2 Aufnahmebohrungen in Reihenschaltung

2LHD1-...-B..

Gewicht: s. Tabelle

Nenndruck: 250 bar (A)
350 bar (S)

Aufnahmebohrung
siehe Massblatt-Nr.:
IK-100-000

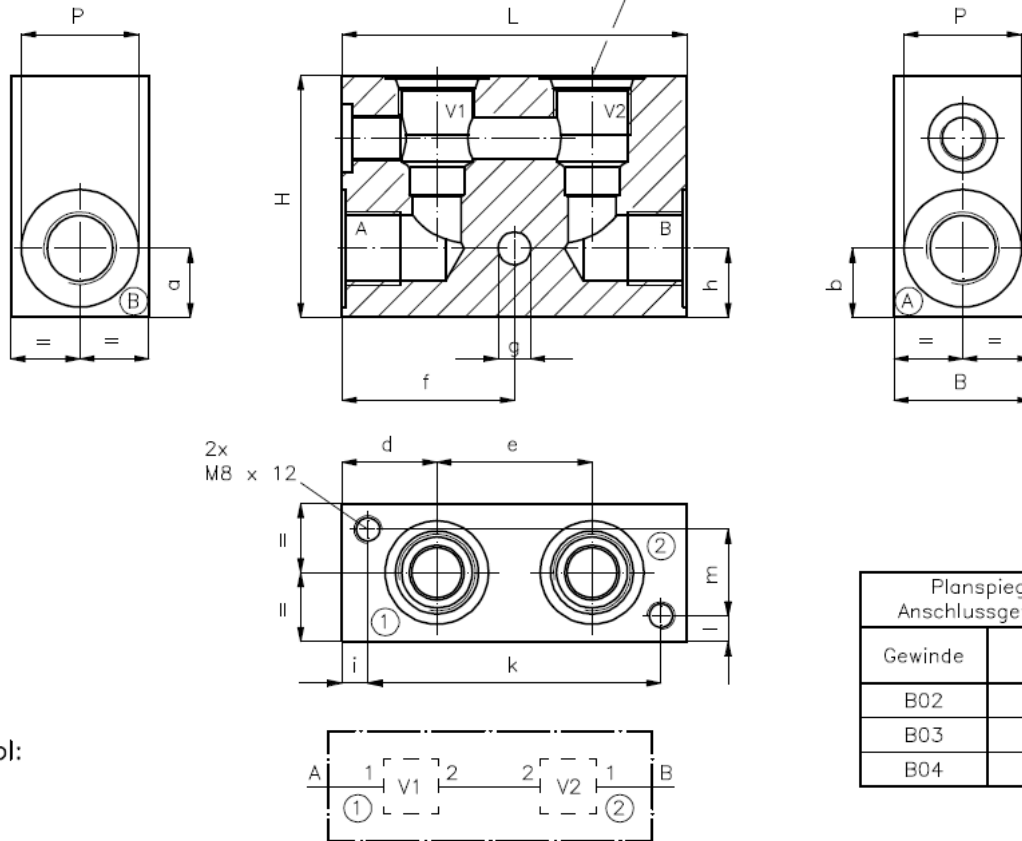

Symbol:

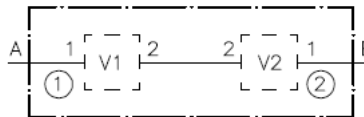

Typ	L	B	H	a	b	d	e	f	g	h	i	k	l	m	Gew.(kg)	
															A	S
2LHD1-08.-B..																
2LHD1-10.-B..	100	40	70	20	20	27.5	45	50	9.5	20	7.5	85	7.5	25	0.65	
2LHD1-12.-B..																
2LHD1-16.-B..																
2LHD1-20.-B..																

Bestell-Schlüssel:

Bestell-Beispiel:

2LHD1-10A-B04

