

Mehrzweck-Gehäuse-Zwischenplatte NG 16 (von P2 nach T1)

MGZ-16.-P2/T1/16-08

Gewicht: ca. 2.8 kg (A)
ca. 8.4 kg (S)

Nenndruck: 250 bar (A)
350 bar (S)

Aufnahmebohrung
C-16-2
siehe Massblatt-Nr.:
IK-100-169

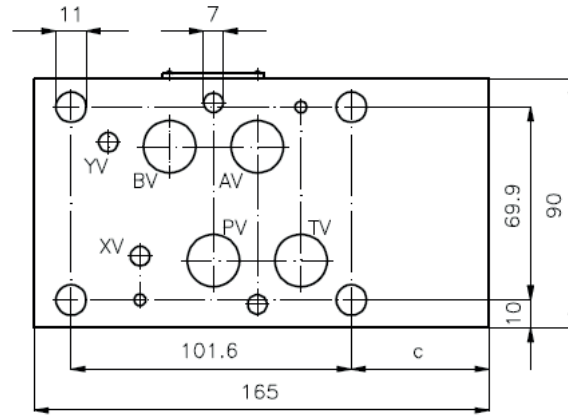
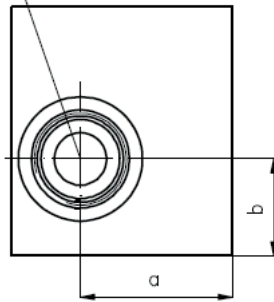

MGZ-16.-P2/T1
MGZ-16.-A2/T1
MGZ-16.-B2/T1

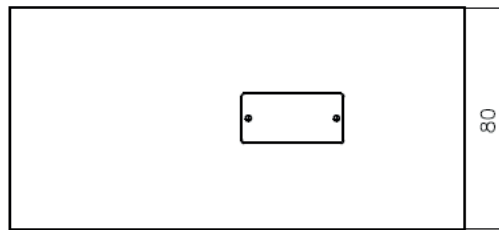

MGZ-16.-PM1/PV2+PD-B08

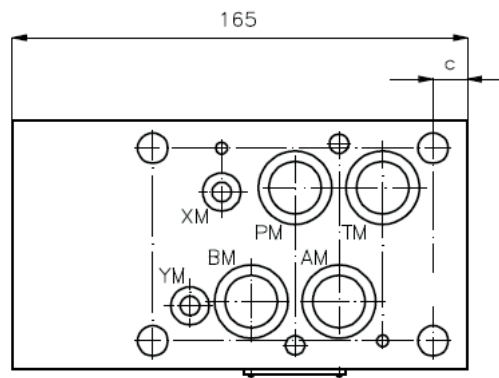
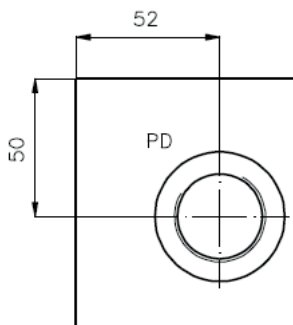

MGZ-16.-PM2/PV1
MGZ-16.-BM2/BV1
MGZ-16.-BM2/BV1+A

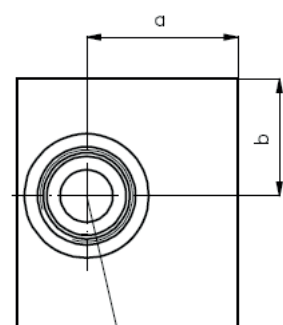

Aufnahmebohrung
C-16-2
siehe Massblatt-Nr.:
IK-100-169

Typ	a	b	c
MGZ-16.-PM1/PV2+PD-B08	25	42.5	15
MGZ-16.-PM2/PV1	55	42.5	12.5
MGZ-16.-P2/T1	55	45	50
MGZ-16.-A2/T1	50	35	50
MGZ-16.-BM2/BV1	55	45	12.5
MGZ-16.-B2/T1	50	45	50

Mehrzweck-Gehäuse-Zwischenplatte NG 16 (von P2 nach T1)

MGZ-16.-P2/T1/16-08

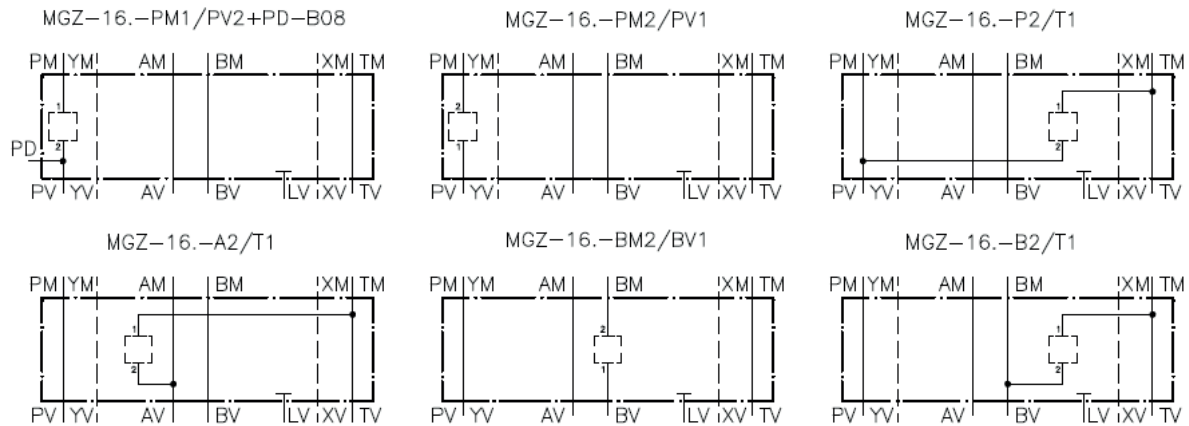

Bestell-Schlüssel:

Bestell-Beispiel:

MGZ-16A-A2/T1

Geraeteeausfuehrung _____ Ausfuehrung

Baugroesse und Werkstoff _____

16A = Alu (F 37)

16S = Stahl (9SMnPb28K bzw. GGG-40)

Zum Lieferumfang gehoeren: 4 Stck. O-Ring 22.22 x 2.62
2 Stck. O-Ring 9.19 x 2.62