

# 3 way, 2 position screw-in valve piston-type "D" (positive)

DCPS-10.-D-.-0-...

**CD-340-101-00**

(subject to change)

**BUCHER**  
hydraulics

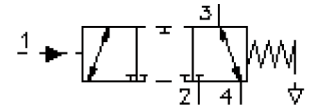

(closed center position)

HEX 19 mm

HEX 27 mm  
(torque  
cartridge:  
48 - 54 Nm)

cavity:  
C-10-4  
see  
data-sheet no.:  
IK-400-109-00

HEW 8 mm

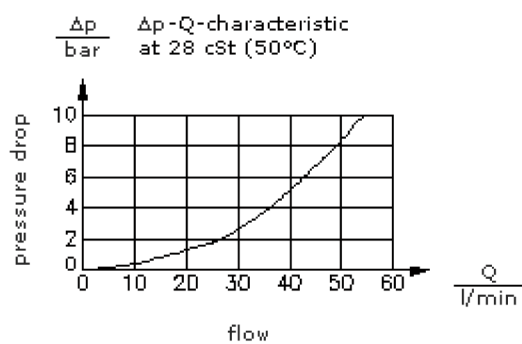
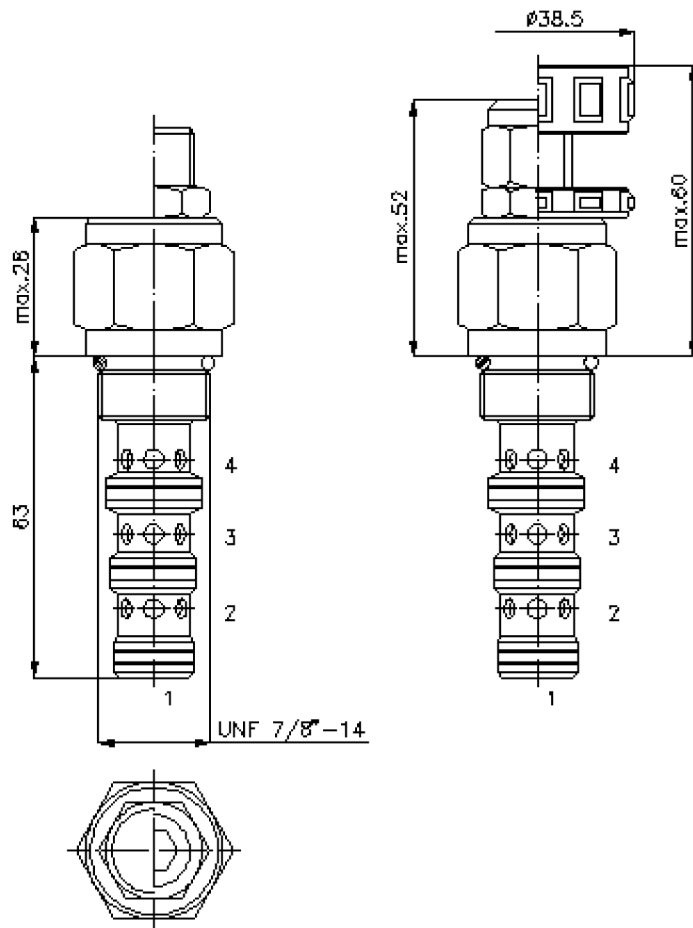

# 3 way, 2 position screw-in valve piston-type "D" (positive)

DCPS-10.-D-.-0-...



Motrac Hydraulik GmbH  
Siemensring 87 - D-47877 Willich  
fon +49-(0)2154-8162.0 - fax +49-(0)2154-8162.499  
e-mail info.mhw@motracindustries.com  
internet www.motracindustries.com

CD-340-101-00

(subject to change)

**BUCHER**  
hydraulics

## Ordering example:

DCPS - 10N - D - C - 0 - 200  
|        |        |        |        |        |  
**A**    **B**    **C**    **D**    **E**    **F**

## Model code:

- |  |   |
|--|---|
| <p><b>A design</b><br/>directional valve<br/>hydraulic release<br/>spring centered<br/>spool type valve</p> <p><b>B size and sealing</b><br/>10N = Buna (NBR)<br/>10V = Viton (FPM)</p> <p><b>C spool type</b><br/>D = closed center position</p> <p><b>D adjustment</b><br/>F = fixed<br/>S = screw adjustment<br/>C = cap<br/>K = handknob</p> | <p><b>E construction</b><br/>0 = screw-in valve</p> <p><b>F pilot pressure</b><br/>070 = 4.8 bar ("F" only)<br/>100 = 6.9 bar ("F" only)<br/>200 = 5.2 -13.8 bar ("S" only)</p> |
|--|---|

## Technical Data:

<b>note:</b>	Pilot oil must be higher than crack pressure + pressure at port 4.
<b>nominal pressure:</b>	350 bar
<b>nominal flow:</b>	45 l/min
<b>weight:</b>	0.21 kg
<b>temperature range:</b>	-40°C to 120°C
<b>fluids:</b>	hydraulic oil as per DIN 51524 T1 (ISO TC 131)
<b>max. leakage:</b>	85 ccm/min at 22 cSt (50°C)
<b>seals:</b>	optional Buna (NBR) or Viton (FPM), as well as Teflon wascher (PTFE)
<b>cavity:</b>	C-10-4 see datasheet no. <a href="#">IK-400-109-00</a> Review note!
<b>housing:</b>	4LH-10.-B.. see datasheet no. <a href="#">IH-400-000-00</a>
<b>seal kit:</b>	SP-CDS-10N-13 (NBR), SP-CDS-10V-13 (FPM)